



Welding cylinder

Lateral flange, retract and working stroke

Version: 2011-01

**bilateral air connection,
double-stage pressurized**

undamped

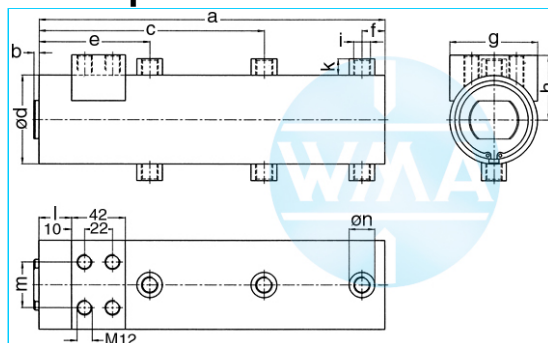

Nominal size 038

S	WS	a	b	c	d	e	f	g	h	i	k	l	m	n	Force*	Order-number
50	30	369	4	254	48	126	18	48	40	Rp1/4"	13	25	24	20	0.2 kN	105.117.124.038.050.
60	20	379	4	254	48	126	18	48	40	Rp1/4"	13	25	24	20	0.2 kN	105.117.124.038.060.
70	30	429	4	294	48	146	18	48	40	Rp1/4"	13	25	24	20	0.2 kN	105.117.124.038.070.
80	20	439	4	294	48	146	18	48	40	Rp1/4"	13	25	24	20	0.2 kN	105.117.124.038.080.
90	40	509	4	354	48	176	18	48	40	Rp1/4"	13	25	24	20	0.2 kN	105.117.124.038.090.
100	30	519	4	354	48	176	18	48	40	Rp1/4"	13	25	24	20	0.2 kN	105.117.124.038.100.
110	40	569	4	394	48	196	18	48	40	Rp1/4"	13	25	24	20	0.2 kN	105.117.124.038.110.

S = retract, WS = working stroke, *at 1 bar pressure

Nominal size 044

S	WS	a	b	c	d	e	f	g	h	i	k	l	m	n	Force*	Order-number
50	30	369	4	254	55	126	18	55	44	Rp1/4"	13	25	30	20	0.28 kN	105.117.124.044.050.
60	20	379	4	254	55	126	18	55	44	Rp1/4"	13	25	30	20	0.28 kN	105.117.124.044.060.
70	30	429	4	294	55	146	18	55	44	Rp1/4"	13	25	30	20	0.28 kN	105.117.124.044.070.
80	20	439	4	294	55	146	18	55	44	Rp1/4"	13	25	30	20	0.28 kN	105.117.124.044.080.
90	40	509	4	354	55	176	18	55	44	Rp1/4"	13	25	30	20	0.28 kN	105.117.124.044.090.
100	30	519	4	354	55	176	18	55	44	Rp1/4"	13	25	30	20	0.28 kN	105.117.124.044.100.
110	40	569	4	394	55	196	18	55	44	Rp1/4"	13	25	30	20	0.28 kN	105.117.124.044.110.

S = retract, WS = working stroke, *at 1 bar pressure

Nominal size 058

S	WS	a	b	c	d	e	f	g	h	i	k	l	m	n	Force*	Order-number
50	30	369	4	254	70	126	18	70	51	Rp1/4"	13	25	36	20	0.5 kN	105.117.124.058.050.
60	20	379	4	254	70	126	18	70	51	Rp1/4"	13	25	36	20	0.5 kN	105.117.124.058.060.
70	30	429	4	294	70	146	18	70	51	Rp1/4"	13	25	36	20	0.5 kN	105.117.124.058.070.
80	20	439	4	294	70	146	18	70	51	Rp1/4"	13	25	36	20	0.5 kN	105.117.124.058.080.
90	40	509	4	354	70	176	18	70	51	Rp1/4"	13	25	36	20	0.5 kN	105.117.124.058.090.
100	30	519	4	354	70	176	18	70	51	Rp1/4"	13	25	36	20	0.5 kN	105.117.124.058.100.
110	40	569	4	394	70	196	18	70	51	Rp1/4"	13	25	36	20	0.5 kN	105.117.124.058.110.

S = retract, WS = working stroke, *at 1 bar pressure

Complete the Order-number:

Example: 105.117.124.058.050.??? No. Force connection (S.5).?? No. Cylinder rod (S.6)!

We reserve the right to make changes which are in the interest of technical progress.

© by WMA Schmidt & Bittner GmbH, Baumwaide 23, D-74360 Ilfeld-Auenstein, Tel. +49 7062 9066-0, Fax +49 7062 9066-20

info@wma-sb.de or wma-sb@t-online.de, <http://www.wma-sb.de>

Cylinder-lateral flange-1



Welding cylinder

Lateral flange, retract and working stroke

Version: 2011-01

**bilateral air connection,
double-stage pressurized**

undamped

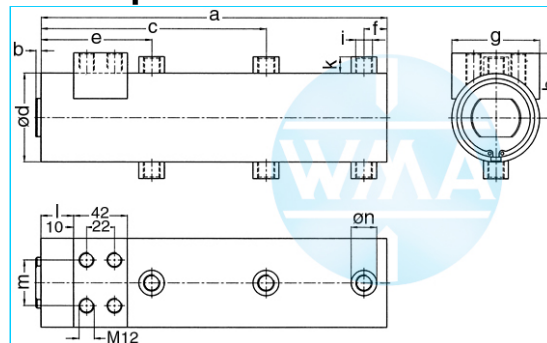

Nominal size 070

S	WS	a	b	c	d	e	f	g	h	i	k	l	m	n	Force*	Order-number
50	30	419	4	293	90	143	24	90	60	Rp3/8"	16	29	66	25	0.72 kN	105.117.124.070.050.
60	20	429	4	293	90	143	24	90	60	Rp3/8"	16	29	66	25	0.72 kN	105.117.124.070.060.
70	30	479	4	333	90	163	24	90	60	Rp3/8"	16	29	66	25	0.72 kN	105.117.124.070.070.
80	20	489	4	333	90	163	24	90	60	Rp3/8"	16	29	66	25	0.72 kN	105.117.124.070.080.
90	40	559	4	393	90	193	24	90	60	Rp3/8"	16	29	66	25	0.72 kN	105.117.124.070.090.
100	30	569	4	393	90	193	24	90	60	Rp3/8"	16	29	66	25	0.72 kN	105.117.124.070.100.
110	40	619	4	433	90	213	24	90	60	Rp3/8"	16	29	66	25	0.72 kN	105.117.124.070.110.

S = retract, WS = working stroke, *at 1 bar pressure

Nominal size 080

S	WS	a	b	c	d	e	f	g	h	i	k	l	m	n	Force*	Order-number
50	30	419	4	293	100	143	24	100	65	Rp3/8"	16	29	76	25	0.95 kN	105.117.124.080.050.
60	20	429	4	293	100	143	24	100	65	Rp3/8"	16	29	76	25	0.95 kN	105.117.124.080.060.
70	30	479	4	333	100	163	24	100	65	Rp3/8"	16	29	76	25	0.95 kN	105.117.124.080.070.
80	20	489	4	333	100	163	24	100	65	Rp3/8"	16	29	76	25	0.95 kN	105.117.124.080.080.
90	40	559	4	393	100	193	24	100	65	Rp3/8"	16	29	76	25	0.95 kN	105.117.124.080.090.
100	30	569	4	393	100	193	24	100	65	Rp3/8"	16	29	76	25	0.95 kN	105.117.124.080.100.
110	40	619	4	433	100	213	24	100	65	Rp3/8"	16	29	76	25	0.95 kN	105.117.124.080.110.

S = retract, WS = working stroke, *at 1 bar pressure

Nominal size 090

S	WS	a	b	c	d	e	f	g	h	i	k	l	m	n	Force*	Order-number
50	30	419	4	293	110	143	24	110	70	Rp3/8"	16	29	86	25	1.2 kN	105.117.124.090.050.
60	20	429	4	293	110	143	24	110	70	Rp3/8"	16	29	86	25	1.2 kN	105.117.124.090.060.
70	30	479	4	333	110	163	24	110	70	Rp3/8"	16	29	86	25	1.2 kN	105.117.124.090.070.
80	20	489	4	333	110	163	24	110	70	Rp3/8"	16	29	86	25	1.2 kN	105.117.124.090.080.
90	40	559	4	393	110	193	24	110	70	Rp3/8"	16	29	86	25	1.2 kN	105.117.124.090.090.
100	30	569	4	393	110	193	24	110	70	Rp3/8"	16	29	86	25	1.2 kN	105.117.124.090.100.
110	40	619	4	433	110	213	24	110	70	Rp3/8"	16	29	86	25	1.2 kN	105.117.124.090.110.

S = retract, WS = working stroke, *at 1 bar pressure

Complete the Order-number:

Example: 105.117.124.080.070.??? No. Force connection (S.5).?? No. Cylinder rod (S.6)!

We reserve the right to make changes which are in the interest of technical progress.

© by WMA Schmidt & Bittner GmbH, Baumwaide 23, D-74360 Ilfeld-Auenstein, Tel. +49 7062 9066-0, Fax +49 7062 9066-20

info@wma-sb.de or wma-sb@t-online.de, <http://www.wma-sb.de>

Cylinder-lateral flange-2



Welding cylinder

Lateral flange, retract and working stroke

Version: 2011-01

**bilateral air connection,
double-stage pressurized**

damped independent of stroke

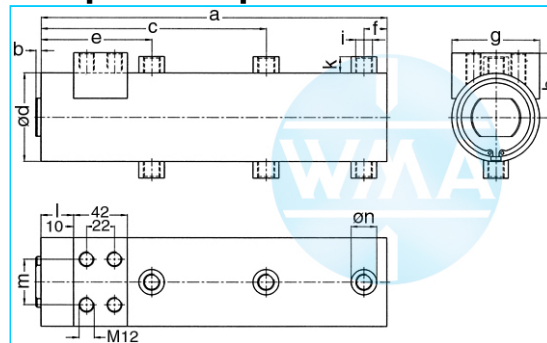

Nominal size 044

S	WS	a	b	c	d	e	f	g	h	i	k	l	m	n	Force*	Order-number
50	30	369	4	254	55	126	18	55	44	Rp1/4"	13	25	30	20	0.28 kN	105.117.125.044.050.
60	20	379	4	254	55	126	18	55	44	Rp1/4"	13	25	30	20	0.28 kN	105.117.125.044.060.
70	30	429	4	294	55	146	18	55	44	Rp1/4"	13	25	30	20	0.28 kN	105.117.125.044.070.
80	20	439	4	294	55	146	18	55	44	Rp1/4"	13	25	30	20	0.28 kN	105.117.125.044.080.
90	40	509	4	354	55	176	18	55	44	Rp1/4"	13	25	30	20	0.28 kN	105.117.125.044.090.
100	30	519	4	354	55	176	18	55	44	Rp1/4"	13	25	30	20	0.28 kN	105.117.125.044.100.
110	40	569	4	394	55	196	18	55	44	Rp1/4"	13	25	30	20	0.28 kN	105.117.125.044.110.

S = retract, WS = working stroke, *at 1 bar pressure

Nominal size 058

S	WS	a	b	c	d	e	f	g	h	i	k	l	m	n	Force*	Order-number
50	30	369	4	254	70	126	18	70	51	Rp1/4"	13	25	36	20	0.5 kN	105.117.125.058.050.
60	20	379	4	254	70	126	18	70	51	Rp1/4"	13	25	36	20	0.5 kN	105.117.125.058.060.
70	30	429	4	294	70	146	18	70	51	Rp1/4"	13	25	36	20	0.5 kN	105.117.125.058.070.
80	20	439	4	294	70	146	18	70	51	Rp1/4"	13	25	36	20	0.5 kN	105.117.125.058.080.
90	40	509	4	354	70	176	18	70	51	Rp1/4"	13	25	36	20	0.5 kN	105.117.125.058.090.
100	30	519	4	354	70	176	18	70	51	Rp1/4"	13	25	36	20	0.5 kN	105.117.125.058.100.
110	40	569	4	394	70	196	18	70	51	Rp1/4"	13	25	36	20	0.5 kN	105.117.125.058.110.

S = retract, WS = working stroke, *at 1 bar pressure

Nominal size 070

S	WS	a	b	c	d	e	f	g	h	i	k	l	m	n	Force*	Order-number
50	30	419	4	293	90	143	24	90	60	Rp3/8"	16	29	66	25	0.72 kN	105.117.125.070.050.
60	20	429	4	293	90	143	24	90	60	Rp3/8"	16	29	66	25	0.72 kN	105.117.125.070.060.
70	30	479	4	333	90	163	24	90	60	Rp3/8"	16	29	66	25	0.72 kN	105.117.125.070.070.
80	20	489	4	333	90	163	24	90	60	Rp3/8"	16	29	66	25	0.72 kN	105.117.125.070.080.
90	40	559	4	393	90	193	24	90	60	Rp3/8"	16	29	66	25	0.72 kN	105.117.125.070.090.
100	30	569	4	393	90	193	24	90	60	Rp3/8"	16	29	66	25	0.72 kN	105.117.125.070.100.
110	40	619	4	433	90	213	24	90	60	Rp3/8"	16	29	66	25	0.72 kN	105.117.125.070.110.

S = retract, WS = working stroke, *at 1 bar pressure

Complete the Order-number:

Example: 105.117.125.058.050.??? No. Force connection (S.5).?? No. Cylinder rod (S.6)!

We reserve the right to make changes which are in the interest of technical progress.

© by WMA Schmidt & Bittner GmbH, Baumwaide 23, D-74360 Ilfeld-Auenstein, Tel. +49 7062 9066-0, Fax +49 7062 9066-20

info@wma-sb.de or wma-sb@t-online.de, <http://www.wma-sb.de>

Cylinder-lateral flange-3



Welding cylinder

Lateral flange, retract and working stroke

Version: 2011-01

**bilateral air connection,
double-stage pressurized**

damped independent of stroke

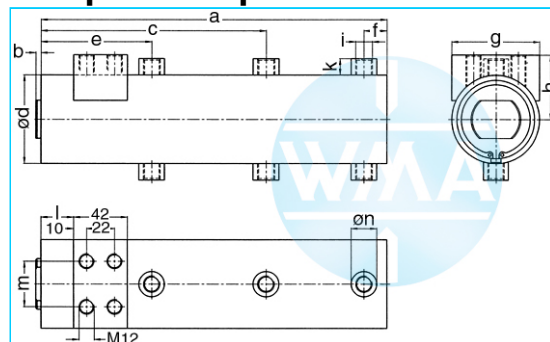

Nominal size 080

S	WS	a	b	c	d	e	f	g	h	i	k	l	m	n	Force*	Order-number
50	30	419	4	293	100	143	24	100	65	Rp3/8"	16	29	76	25	0.95 kN	105.117.125.080.050.
60	20	429	4	293	100	143	24	100	65	Rp3/8"	16	29	76	25	0.95 kN	105.117.125.080.060.
70	30	479	4	333	100	163	24	100	65	Rp3/8"	16	29	76	25	0.95 kN	105.117.125.080.070.
80	20	489	4	333	100	163	24	100	65	Rp3/8"	16	29	76	25	0.95 kN	105.117.125.080.080.
90	40	559	4	393	100	193	24	100	65	Rp3/8"	16	29	76	25	0.95 kN	105.117.125.080.090.
100	30	569	4	393	100	193	24	100	65	Rp3/8"	16	29	76	25	0.95 kN	105.117.125.080.100.
110	40	619	4	433	100	213	24	100	65	Rp3/8"	16	29	76	25	0.95 kN	105.117.125.080.110.

S = retract, WS = working stroke, *at 1 bar pressure

Nominal size 090

S	WS	a	b	c	d	e	f	g	h	i	k	l	m	n	Force*	Order-number
50	30	419	4	293	110	143	24	110	70	Rp3/8"	16	29	86	25	1.2 kN	105.117.125.090.050.
60	20	429	4	293	110	143	24	110	70	Rp3/8"	16	29	86	25	1.2 kN	105.117.125.090.060.
70	30	479	4	333	110	163	24	110	70	Rp3/8"	16	29	86	25	1.2 kN	105.117.125.090.070.
80	20	489	4	333	110	163	24	110	70	Rp3/8"	16	29	86	25	1.2 kN	105.117.125.090.080.
90	40	559	4	393	110	193	24	110	70	Rp3/8"	16	29	86	25	1.2 kN	105.117.125.090.090.
100	30	569	4	393	110	193	24	110	70	Rp3/8"	16	29	86	25	1.2 kN	105.117.125.090.100.
110	40	619	4	433	110	213	24	110	70	Rp3/8"	16	29	86	25	1.2 kN	105.117.125.090.110.

S = retract, WS = working stroke, *at 1 bar pressure

Complete the Order-number:

Example: 105.117.125.080.070.??? No. Force connection (S.5).?? No. Cylinder rod (S.6)!

We reserve the right to make changes which are in the interest of technical progress.

© by WMA Schmidt & Bittner GmbH, Baumwaide 23, D-74360 Illfeld-Auenstein, Tel. +49 7062 9066-0, Fax +49 7062 9066-20

info@wma-sb.de or wma-sb@t-online.de, <http://www.wma-sb.de>

Cylinder-lateral flange-4



Welding cylinder

Lateral flange, retract and working stroke

Version: 2011-01

Force connection

Write the number (with point) from the selected Force connection direct behind the Order-number of the cylinder and complete the whole Order-number with the chosen number of the Cylinder rod.

Example: 105.117.125.058.050.202.?? No. Cylinder rod (S.6)

Internal cone

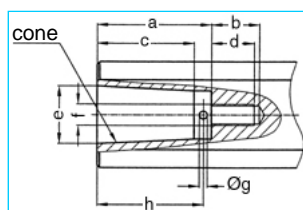

a	b	c	d	e	cone	f	g	h	No.
33	18	27.0	16	17.780	MK2	M8	3	30	101.
42	18	35.5	16	21.806	MK3	M8	3	39	102.
42	18	35.5	16	21.750	1:10	M8	3	39	103.

Female thread

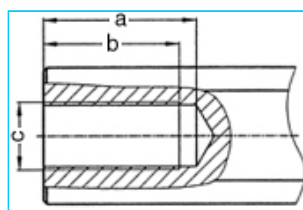

a	b	c	No.
45	40	M20 x 1.5	201.
62	58	M20 x 1.5	202.

Male thread

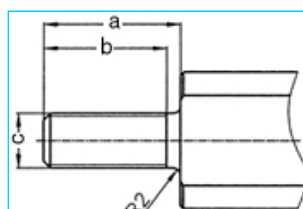

a	b	c	No.
40	36	M16 x 1.5	301.
40	36	M20 x 1.5	302.
40	36	M24 x 1.5	303.

Knurl

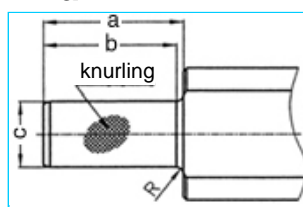

a	b	c	Knurling	R	No.
42	40	20 ¹⁷	1 x 0.2 DIN 82	2	401.
42	42	25 ¹⁷	1 x 0.2 DIN 82	-	402.

We reserve the right to make changes which are in the interest of technical progress.

© by WMA Schmidt & Bittner GmbH, Baumwaide 23, D-74360 Illfeld-Auenstein, Tel. +49 7062 9066-0, Fax +49 7062 9066-20

info@wma-sb.de or wma-sb@t-online.de, <http://www.wma-sb.de>

Cylinder-lateral flange-5



Welding cylinder

Lateral flange, retract and working stroke

Version: 2011-01

Cylinder rod

flattened and rotation locked

Complete the Order-number with the selected number of the chosen cylinder rod.

Example: 105.117.125.058.050.202.01

For piston diameter

70, 80, 90

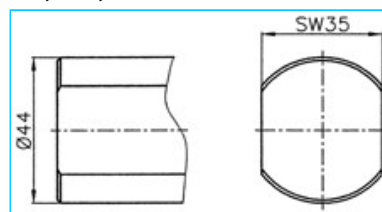

No. 00

For piston diameter

38, 44, 58

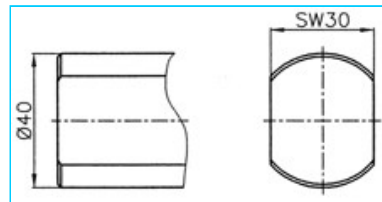

No. 01

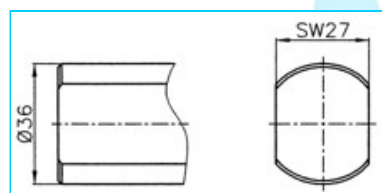

No. 02

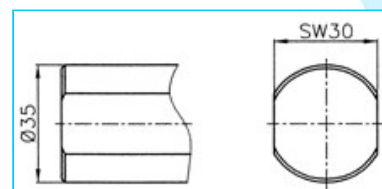

No. 03



Welding cylinder

Lateral flange, retract and working stroke

Version: 2011-01

Electrode holder for welding cylinders

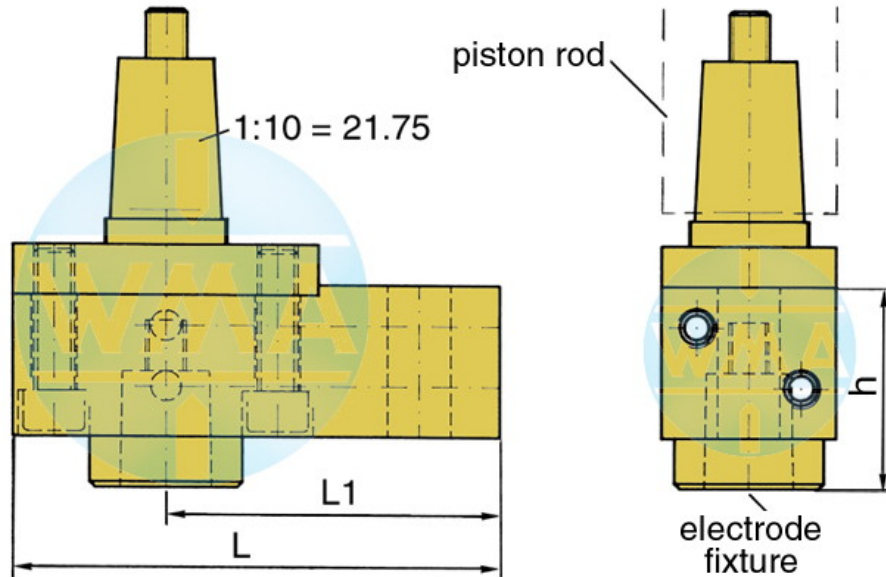

Piston Ø	L	L1	Water connection
38	95	65	possible on both sides
44	95	65	possible on both sides
58	110	80	possible on both sides
70	110	80	possible on both sides
80	120	90	possible on both sides
90	120	90	possible on both sides

Available cones for the electrode fixture

cone	Ø d	h
1 : 10	9.8	39
1 : 10	12.0	39
1 : 10	12.7	39
1 : 10	15.5	39
1 : 10	15.75	39
1 : 10	17.75	50
1 : 10	19.0	50
MK 1	12.065	39
MK 2	17.781	50

Further cones available on request!



Welding cylinder

Lateral flange, retract and working stroke

Version: 2011-01

Electrode holder

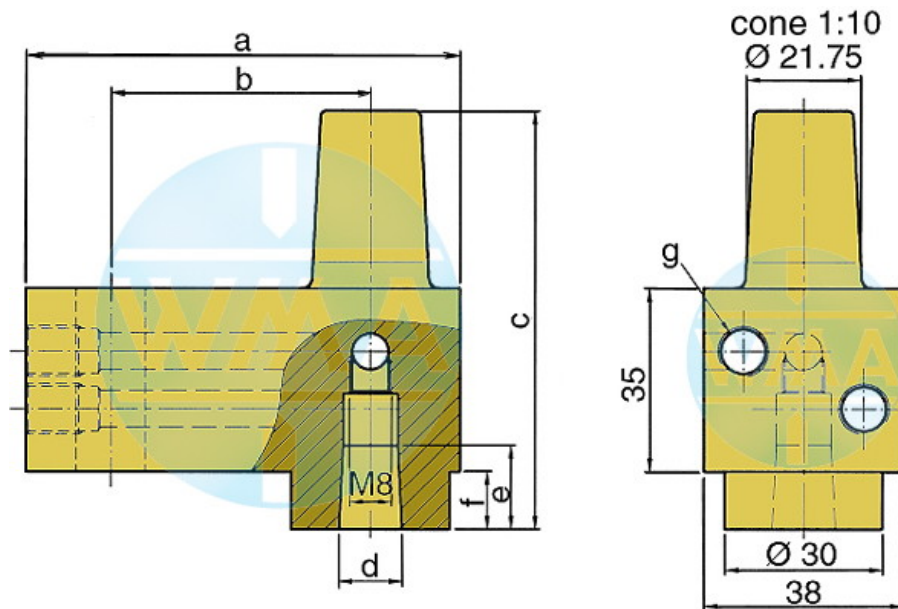

This electrode holder is main used in welding machines with variable and fast-change electrode shafts.

a	b	c	d	e	f	g	Order-number	
82	49	80	1:10=12.00	16	16	11	M10 x 1 or R 1/8"	L60051080-000
82	49	80	MK1	16	16	11	M10 x 1 or R 1/8"	L60091080-000
82	49	80	1:10=15.75	20	20	11	M10 x 1 or R 1/8"	L60131080-001
82	49	80	1:10=18	20	20	11	M10 x 1 or R 1/8"	L60061080-000
82	49	80	MK2	20	20	11	M10 x 1 or R 1/8"	L60101080-000
82	49	90	1:10=21.75	31	31	21	M10 x 1 or R 1/8"	L60221080-000
82	49	90	MK3	31	31	21	M10 x 1 or R 1/8"	L60111080-000
97	64	90	1:10=21.75	31	31	21	M10 x 1 or R 1/8"	L60221090-000
97	64	90	MK3	31	31	21	M10 x 1 or R 1/8"	L60111090-000
107	74	90	1:10=21.75	31	31	21	M10 x 1 or R 1/8"	L60221090-001
107	74	90	MK3	31	31	21	M10 x 1 or R 1/8"	L60111090-001

We reserve the right to make changes which are in the interest of technical progress.

© by WMA Schmidt & Bittner GmbH, Baumwaide 23, D-74360 Illfeld-Auenstein, Tel. +49 7062 9066-0, Fax +49 7062 9066-20

info@wma-sb.de or wma-sb@t-online.de, <http://www.wma-sb.de>

Cylinder-lateral flange-8