



# Welding cylinder

Ground plate, retract and working stroke

Version: 2011-01

**bilateral air connection,  
double-stage pressurized**

**undamped**

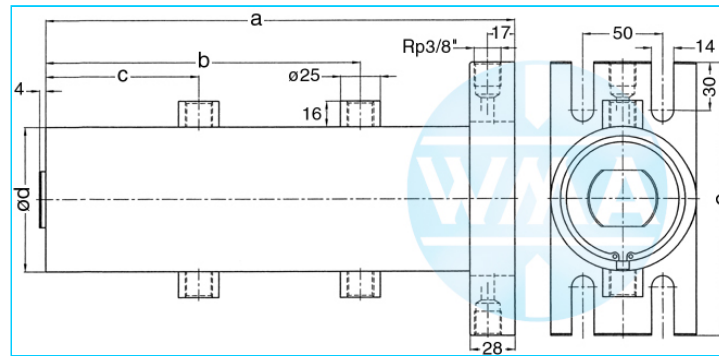

## Nominal size 070

S	WS	a	b	c	d	e	Force*	Order-number
50	30	419	293	143	90	170	0.72 kN	101.115.124.070.050.
60	20	429	293	143	90	170	0.72 kN	101.115.124.070.060.
70	30	479	333	163	90	170	0.72 kN	101.115.124.070.070.
80	20	489	333	163	90	170	0.72 kN	101.115.124.070.080.
90	40	559	393	193	90	170	0.72 kN	101.115.124.070.090.
100	30	569	393	193	90	170	0.72 kN	101.115.124.070.100.
110	40	619	433	213	90	170	0.72 kN	101.115.124.070.110.

S = retract, WS = working stroke, \*at 1 bar pressure

## Nominal size 080

S	WS	a	b	c	d	e	Force*	Order-number
50	30	419	293	143	100	180	0.95 kN	101.115.124.080.050.
60	20	429	293	143	100	180	0.95 kN	101.115.124.080.060.
70	30	479	333	163	100	180	0.95 kN	101.115.124.080.070.
80	20	489	333	163	100	180	0.95 kN	101.115.124.080.080.
90	40	559	393	193	100	180	0.95 kN	101.115.124.080.090.
100	30	569	393	193	100	180	0.95 kN	101.115.124.080.100.
110	40	619	433	213	100	180	0.95 kN	101.115.124.080.110.

S = retract, WS = working stroke, \*at 1 bar pressure

## Nominal size 090

S	WS	a	b	c	d	e	Force*	Order-number
50	30	419	293	143	110	190	1.2 kN	101.115.124.090.050.
60	20	429	293	143	110	190	1.2 kN	101.115.124.090.060.
70	30	479	333	163	110	190	1.2 kN	101.115.124.090.070.
80	20	489	333	163	110	190	1.2 kN	101.115.124.090.080.
90	40	559	393	193	110	190	1.2 kN	101.115.124.090.090.
100	30	569	393	193	110	190	1.2 kN	101.115.124.090.100.
110	40	619	433	213	110	190	1.2 kN	101.115.124.090.110.

S = retract, WS = working stroke, \*at 1 bar pressure

### Complete the Order-number:

Example: 101.115.124.090.050.??? **No. Force connection (S.3)?? No. Cylinder rod (S.4)!**

We reserve the right to make changes which are in the interest of technical progress.

© by WMA Schmidt & Bittner GmbH, Baumwaide 23, D-74360 Illfeld-Auenstein, Tel. +49 7062 9066-0, Fax +49 7062 9066-20

info@wma-sb.de or wma-sb@t-online.de, <http://www.wma-sb.de>

Cylinder-Ground plate-1



# Welding cylinder

Ground plate, retract and working stroke

Version: 2011-01

**bilateral air connection,  
double-stage pressurized**

**damped independent of stroke**

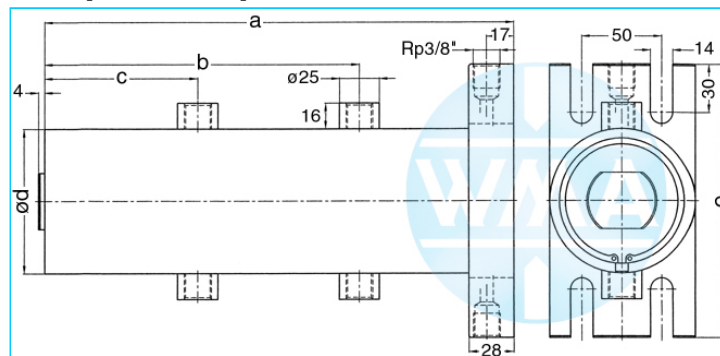

## Nominal size 070

S	WS	a	b	c	d	e	Force*	Order-number
50	30	419	293	143	90	170	0.72 kN	101.115.125.070.050.
60	20	429	293	143	90	170	0.72 kN	101.115.125.070.060.
70	30	479	333	163	90	170	0.72 kN	101.115.125.070.070.
80	20	489	333	163	90	170	0.72 kN	101.115.125.070.080.
90	40	559	393	193	90	170	0.72 kN	101.115.125.070.090.
100	30	569	393	193	90	170	0.72 kN	101.115.125.070.100.
110	40	619	433	213	90	170	0.72 kN	101.115.125.070.110.

S = retract, WS = working stroke, \*at 1 bar pressure

## Nominal size 080

S	WS	a	b	c	d	e	Force*	Order-number
50	30	419	293	143	100	180	0.95 kN	101.115.125.080.050.
60	20	429	293	143	100	180	0.95 kN	101.115.125.080.060.
70	30	479	333	163	100	180	0.95 kN	101.115.125.080.070.
80	20	489	333	163	100	180	0.95 kN	101.115.125.080.080.
90	40	559	393	193	100	180	0.95 kN	101.115.125.080.090.
100	30	569	393	193	100	180	0.95 kN	101.115.125.080.100.
110	40	619	433	213	100	180	0.95 kN	101.115.125.080.110.

S = retract, WS = working stroke, \*at 1 bar pressure

## Nominal size 090

S	WS	a	b	c	d	e	Force*	Order-number
50	30	419	293	143	110	190	1.2 kN	101.115.125.090.050.
60	20	429	293	143	110	190	1.2 kN	101.115.125.090.060.
70	30	479	333	163	110	190	1.2 kN	101.115.125.090.070.
80	20	489	333	163	110	190	1.2 kN	101.115.125.090.080.
90	40	559	393	193	110	190	1.2 kN	101.115.125.090.090.
100	30	569	393	193	110	190	1.2 kN	101.115.125.090.100.
110	40	619	433	213	110	190	1.2 kN	101.115.125.090.110.

S = retract, WS = working stroke, \*at 1 bar pressure

### Complete the Order-number:

Example: 101.115.125.080.050.??? **No. Force connection (S.3).?? No. Cylinder rod (S.4)**

We reserve the right to make changes which are in the interest of technical progress.

© by WMA Schmidt & Bittner GmbH, Baumwaide 23, D-74360 Illfeld-Auenstein, Tel. +49 7062 9066-0, Fax +49 7062 9066-20

info@wma-sb.de or wma-sb@t-online.de, <http://www.wma-sb.de>

Cylinder-Ground plate-2



# Welding cylinder

Ground plate, retract and working stroke

Version: 2011-01

## Force connection

Write the number (with point) from the selected Force connection direct behind the Order-number of the cylinder and complete the whole Order-number with the chosen number of the Cylinder rod.

**Example: 101.115.125.080.050.102.?? No. Cylinder rod (S.4)**

### Internal cone

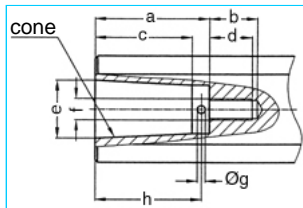

a	b	c	d	e	cone	f	g	h	No.
33	18	27.0	16	17.780	MK2	M8	3	30	<b>101.</b>
42	18	35.5	16	21.806	MK3	M8	3	39	<b>102.</b>
42	18	35.5	16	21.750	1:10	M8	3	39	<b>103.</b>

### Female thread

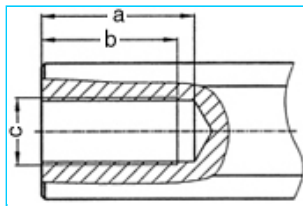

a	b	c	No.
45	40	M20 x 1.5	<b>201.</b>
62	58	M20 x 1.5	<b>202.</b>

### Male thread

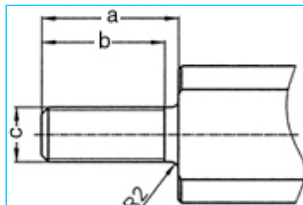

a	b	c	No.
40	36	M16 x 1.5	<b>301.</b>
40	36	M20 x 1.5	<b>302.</b>
40	36	M24 x 1.5	<b>303.</b>

### Knurl

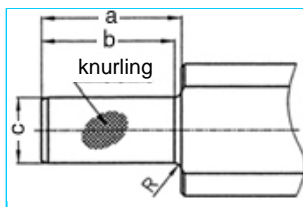

a	b	c	Knurling	R	No.
42	40	2017	1 x 0.2 DIN 82	2	<b>401.</b>
42	42	2517	1 x 0.2 DIN 82	-	<b>402.</b>



# Welding cylinder

Ground plate, retract and working stroke

Version: 2011-01

## Cylinder rod

flattened and rotation locked

Complete the Order-number with the selected number of the chosen cylinder rod.

**Example: 101.115.125.080.050.102.00**

### For piston diameter

70, 80, 90

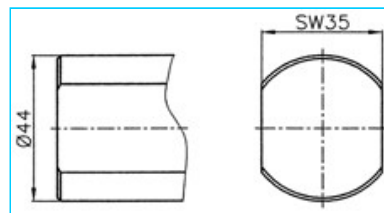

**No. 00**

### For piston diameter

38, 44, 58

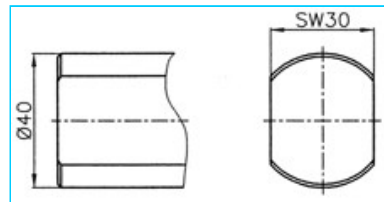

**No. 01**

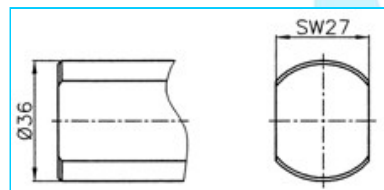

**No. 02**

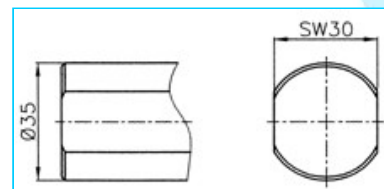

**No. 03**



# Welding cylinder

Ground plate, retract and working stroke

Version: 2011-01

## Electrode holder for welding cylinders

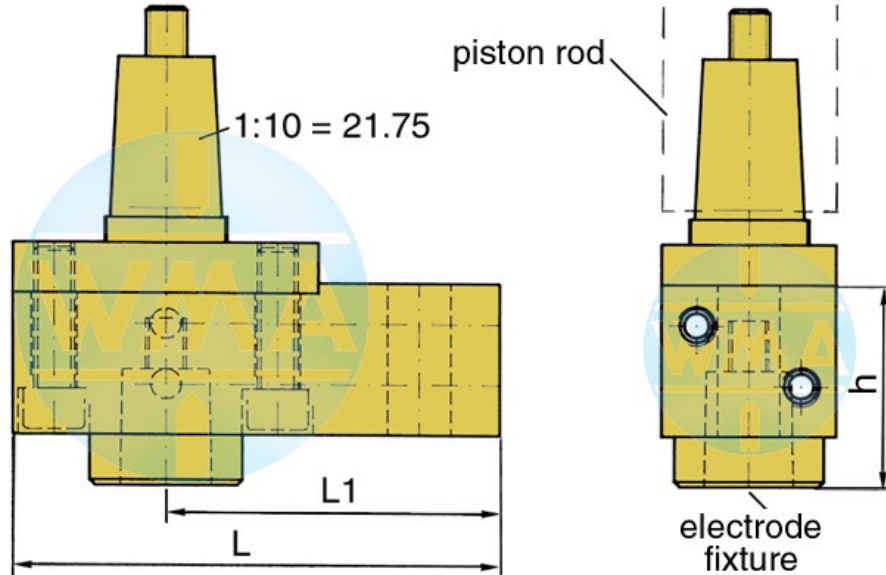

Piston Ø	L	L1	Water connection
38	95	65	possible on both sides
44	95	65	possible on both sides
58	110	80	possible on both sides
70	110	80	possible on both sides
80	120	90	possible on both sides
90	120	90	possible on both sides

## Available cones for the electrode fixture

cone	Ø d	h
1 : 10	9.8	39
1 : 10	12.0	39
1 : 10	12.7	39
1 : 10	15.5	39
1 : 10	15.75	39
1 : 10	17.75	50
1 : 10	19.0	50
MK 1	12.065	39
MK 2	17.781	50

Further cones available on request!



# Welding cylinder

Ground plate, retract and working stroke

Version: 2011-01

## Electrode holder

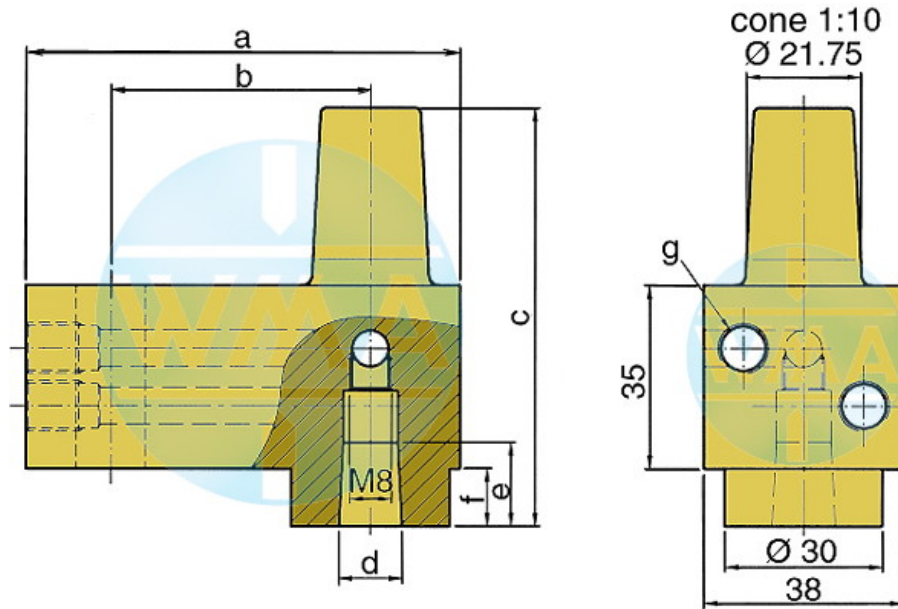

This electrode holder is main used in welding machines with variable and fast-change electrode shafts.

a	b	c	d	e	f	g	Order-number	
82	49	80	1:10=12.00	16	16	11	M10 x 1 or R 1/8"	L60051080-000
82	49	80	MK1	16	16	11	M10 x 1 or R 1/8"	L60091080-000
82	49	80	1:10=15.75	20	20	11	M10 x 1 or R 1/8"	L60131080-001
82	49	80	1:10=18	20	20	11	M10 x 1 or R 1/8"	L60061080-000
82	49	80	MK2	20	20	11	M10 x 1 or R 1/8"	L60101080-000
82	49	90	1:10=21.75	31	31	21	M10 x 1 or R 1/8"	L60221080-000
82	49	90	MK3	31	31	21	M10 x 1 or R 1/8"	L60111080-000
97	64	90	1:10=21.75	31	31	21	M10 x 1 or R 1/8"	L60221090-000
97	64	90	MK3	31	31	21	M10 x 1 or R 1/8"	L60111090-000
107	74	90	1:10=21.75	31	31	21	M10 x 1 or R 1/8"	L60221090-001
107	74	90	MK3	31	31	21	M10 x 1 or R 1/8"	L60111090-001

We reserve the right to make changes which are in the interest of technical progress.

© by WMA Schmidt & Bittner GmbH, Baumwaide 23, D-74360 Illfeld-Auenstein, Tel. +49 7062 9066-0, Fax +49 7062 9066-20

info@wma-sb.de or wma-sb@t-online.de, <http://www.wma-sb.de>

Cylinder-Ground plate-6